

LS-LEDS700T Solar Integrated Post-top



All-in-one integrated smart solar post-top is the perfect solution for urban lighting. Its sleek design meets a wide range of application needs from pathways, parks to compounds as well as blends harmoniously into a wide variety of architectural contexts. There is no trenching and grid cabling work on site. IP65 plug and play connection allows quick and easy installation.

It enjoys a smart and unique design together with the best components available on the market. Using LiFePo4 Battery, MPPT controller make it the most powerful and reliable solar urban lighting solution. With a high tightness level and robust design, this luminaire is built to withstand harsh environmental conditions and vandalism to perform over time. High-pressure die cast aluminium housing finished with integrated Mono-Si solar module which has 25 years anticipated life span, it gives long lasting and optimised illumination with 100% energy savings.

The luminaire reaches 3 days operation time with additional benefits include built-in motion sensor and programmable time dimming offer longer discharge time and optimum performance. The luminaire also complies with the dark sky requirement with low upward lighting pollution.

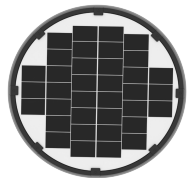
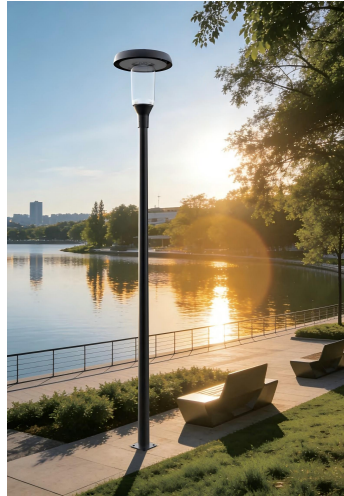

High efficiency mono-crystalline solar panels protected by tempered glass



Using Iron Phosphate Lithium LiFePo4 battery, superior safety. Built-in protection for over-charge, over discharge, over current and over temperature



Suitable for Ø76mm or Ø60mm column entry

Product information

Mono-crystalline high-efficiency cells solar module / Lithium Iron Phosphate (LiFePO4) battery / Electronic protection battery management system / MPPT solar charge controller / CE, UKCA & RoHS international standards / Environmentally friendly & part recyclable: no mercury or other hazardous materials used / Integrated temperature & motion sensors / Robust aluminium structure with light weight / Complies with EN60598

Code	Solar Module†	Lumen Output Maximum	LiFePO4 Battery	Control Mode	Discharge Time* Maximum	Nett Weight	Windage
LS-LEDS700T	30W/18V	2,250lm	205WH /12.8V 16AH	D2D / STD / TC	> 3 days	9.00kg	0.14m ²

† Calculations are done with the 3 hours of Peak Sun Hour

* Calculations are done with 12 hours of operation per day, detection of movement is 5 times per hour

Autonomy and Operation time calculations are only indicative and will depend on several variable factors

Dimensions and mounting

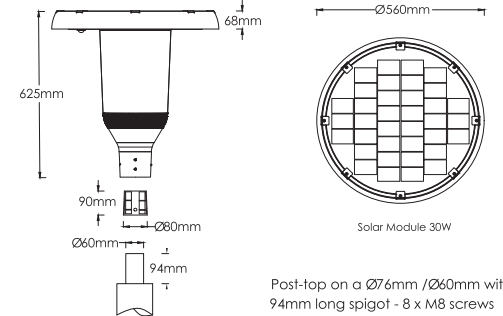

Control Mode Program

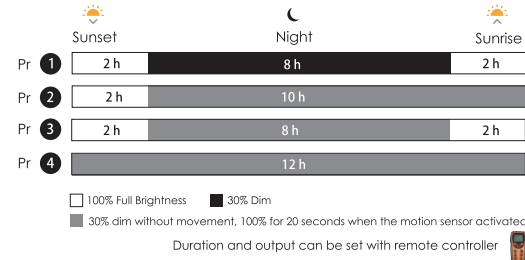

Photometric distribution

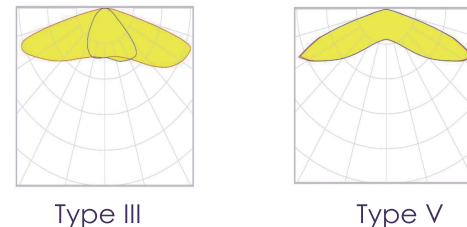

Technical Specification

Beam Angle: TypeIII / TypeV
 Luminous Efficacy: 150lm/W
 Color Rendering Index: ≥80Ra
 LED Type: LM80 3030LEDs
 PV Module: Mono-crystalline (25 years of anticipated lifespan)
 Battery: LiFePO4 (8 years of anticipated lifespan)
 System Design: 12.8VDC
 Control Mode: D2D (Dusk to Dawn) / STD (Step Dimming with Motion Sensor Override / TC (Time Control)
 Charging Time: 4-6 hours
 Control Mode: D2D / STD / TC
 Operating Temperature: -10°C to 50°C
 Mounting Option: Post-top Slip-over - Ø76mm
 Mounting Height: 3-6m
 Color Temperature: Neutral White 4000K (Others available on request)

Applications:



Benefits -

- Universal application, can be used on any type of aluminium or steel pole

Key Features -

- Aesthetics design to beautify the surroundings
- Truly green lighting solution and 100% energy savings
- Long anticipated lifespan of Mono-Si solar module and LiFePO4 battery
- Quick and easy installation without making electrical connections
- 360° full day charging and no onsite orientation is needed