

LS-LEDS193 Series Solar Street Luminaire



With an integrated Mono-Si solar module and LiFePO4 battery, the All-in-one integrated smart solar LED street lantern makes it easier than ever to meet your sustainability targets. All in a compact housing, you can bring it to both urban and rural areas without access to the electric grid for years to come. The luminaire comes in a range of size and lumen packages, designed for column/post mounting at heights of 3-8m.

With a high tightness level and robust design, this luminaire is built to withstand harsh environmental conditions and vandalism to perform over time. High-pressure die-cast aluminium housing finished with integrated Mono-Si solar panel which has 25 years anticipated life span, it gives long lasting and optimised illumination with no uplight pollution.

All-in-one solar street lantern is made for quick and easy installation without worrying about complicated and frustrating electrical wiring. The luminaire reaches 3 days operation time with additional benefits include fully automated from dusk till dawn, built-in motion sensor and programmable time control to maintain optimum performance. This luminaire also complies with the dark sky requirement with no upward lighting pollution.



Integrated Mono-Si solar panel and LiFePO4 battery



All-in-one compact body, easy to install without making electrical connections



Multiple lumen packages with long operational working hours

Product information

Durable with rated life span L70>50,000 hours / Mono-Si solar panel / LiFePO4 battery / Electronic protection battery management system / No UV or IR emissions / CE, UKCA & RoHS international standards / Environmentally friendly & part recyclable: no mercury or other hazardous materials used / Heavy duty die-cast aluminium housing & polycarbonate lens / Complies with EN60598

Code	Solar Module†	Lumen Output Maximum	LiFePO4 Battery	Control Mode	Discharge Time* Maximum	Nett Weight	Windage
LS-LEDS193	22W/18V	1,500lm	154WH 12.8V/12AH	D2D / STD / TC	> 3 days	5.00kg	0.045m²
LS-LEDS194	36W/18V	3,000lm	205WH 12.8V/16AH	D2D / STD / TC	> 3 days	7.80kg	0.051m²

† Calculations are done with the 3 hours of Peak Sun Hour

* Calculations are done with 12 hours of operation per day, detection of movement is 5 times per hour

Autonomy and Operation time calculations are only indicative and will depend on several variable factors

Dimensions and mounting

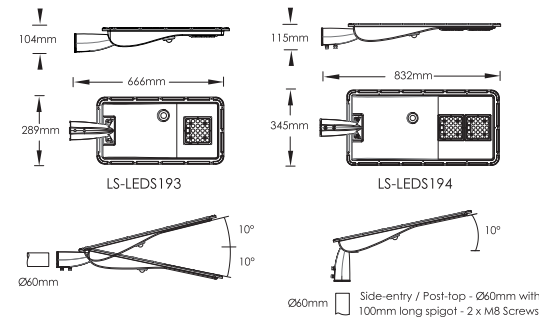

Technical Specification

Beam Angle: Optic SR (Standard Road)
 Luminous Efficacy: 180lm/W
 Color Rendering Index: ≥80Ra
 LED Type: LM80 3030LEDs
 Solar Panel: Mono-si (25 years of anticipated lifespan)
 Battery: LiFePO4 (8 years of anticipated lifespan)
 Solar Charge Controller: MPPT
 Charging Time: 5-6 hours
 Control Mode: D2D (Dusk to Dawn) / STD (Step Dimming with Motion Sensor Override / TC (Time Control)
 Operating Hours: >3 days
 Operating Temperature: -10°C to 50°C
 Mounting Option: Side-entry - Ø60mm
 Post-top - Ø60mm
 Mounting Height: 3-8m
 Color Temperature: Neutral White 4000K
 (Others available on request)

Control Mode Program

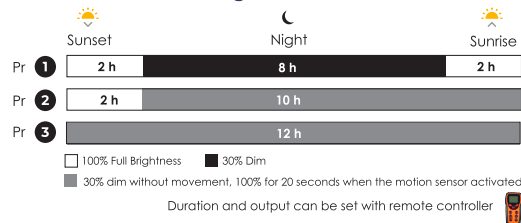

Photometric distribution

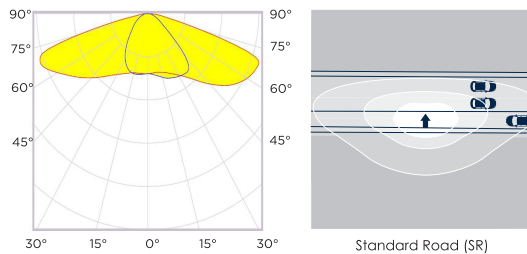

Applications:

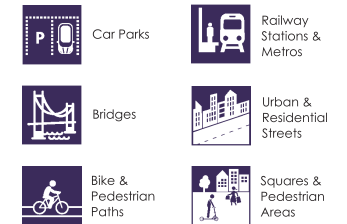

Benefits -

- Ideal for use in the remote areas where mains power is not available

Key Features -

- Truly green lighting solution and 100% energy savings
- Long anticipated lifespan of Mono-Si solar panel and LiFePO4 battery
- Robust design for maintained performance over time
- Quick and easy installation without making electrical connections
- High performance lighting with optimised light distributions designed for exterior areas